



DOMENIUL DE UTILIZARE

- Capacitate de până la **6000 l/min** (360 m³/h)
- Înălțimea de pompare până la **95 m**

LIMITELE DE UTILIZARE

- Înălțimea de aspirație manometrică se ridică până la **7 m**
- Temperatura lichidului de la **-10 °C** până la **+90 °C**
- Presiunea maximă în corpul pompei **10 bar** (PN10)

EXECUTIE ȘI NORME DE SIGURANȚA

EN 733



CERTIFICARI



INSTALAREA ȘI UTILIZAREA

- Alimentare cu apă
- Presurizare
- Irigare
- Circulație a apei din sistemele de aer condiționat
- Instalații de spalare
- Instalații de stingere a incendiilor
- Industrie
- Agricultură

EXECUTII LA CERERE

- Presetupa mecanica speciala
- Contraflansa
- Pompe cu motoare cu o frecvență de 60 Hz
- Pentru lichide cu temperaturi mai mari sau mai mici
- Pentru medii cu temperaturi mai mari sau mici

GARANȚIE

2 ani în funcție de condițiile noastre generale de vânzare

DIMENSIUNI SI GREUTATI

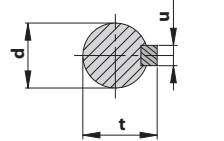
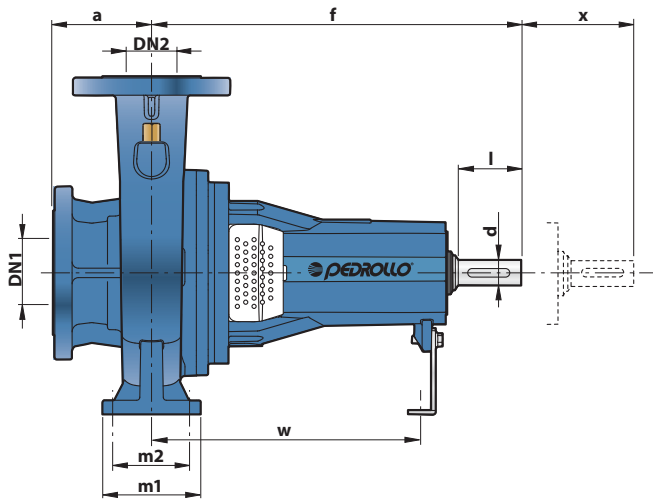

EXTREMITATE ROTOR

mm		
d	u	t
24 k6	8	27
32 k6	10	35

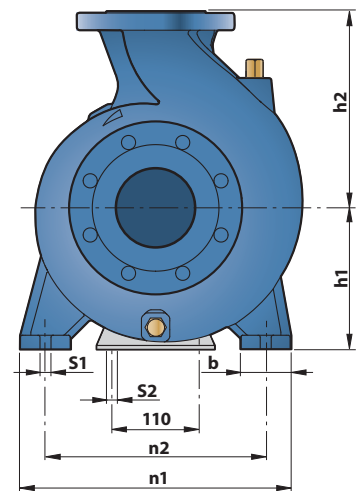

DN FLANȘE	D mm	K mm	GAURI	
			N°	Ø (mm)
32	140	100	4	18
40	150	110		
50	165	125		
65	185	145		
80	200	160	8	18
100	220	180		
125	250	210		

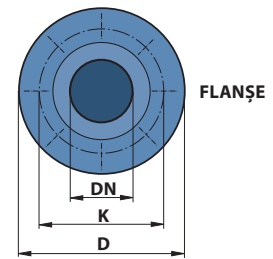

TIP	GURI		DIMENSIUNI mm														kg	
	DN1	DN2	a	f	h1	h2	b	m1	m2	n1	n2	s1	s2	w	x	d		l
FG 32/160	50	32	80	360	132	160	50	100	70	240	190	14	14	260	100	24	50	30.9
FG 32/200					160	180	55	95		245	32.0							
FG 32/200H					160	180	55	100	240	31.4								
FG 40/160	65	40	100	360	132	160	50	100	70	240		14	14	260	100	24	50	29.0
FG 40/200					160	180	55	100		265	212							35.6
FG 40/250					180	225	65	125	95	320	250							44.4
FG 50/125	65	50	100	360	132	160	50	100	70	240	190	14	14	260	100	24	50	28.9
FG 50/160					160	180	55	100		265	212							32.8
FG 50/200					160	200	50											41.3
FG 50/250	180	225	65			320	250	46.6										
FG 65/125	80	65	100	360	160	180	65	125	95	280	212	14	14	260	100	24	50	40.1
FG 65/160					160	200	65											
FG 65/200					180	225	65			320	250							46.5
FG 65/250				470	200	250	80	160	120	360	280	18		340		32	80	67.7
FG 80/160	100	80	125	360	180	225	65	125	95	320	250	14	14	260	140	24	50	45.2
FG 80/200					180	250	65											345
FG 80/250					470	200	280	80		400	315							76.8
FG 100/160	125	100	140	360	200	280	80	160	120	360	280	18	18	260	140	24	50	52.8
FG 100/200					200	280	80											
FG 100/250					470	225	280	80		400	315							84.0

CAMPUL DE PRESTATIE

HS= 0 m

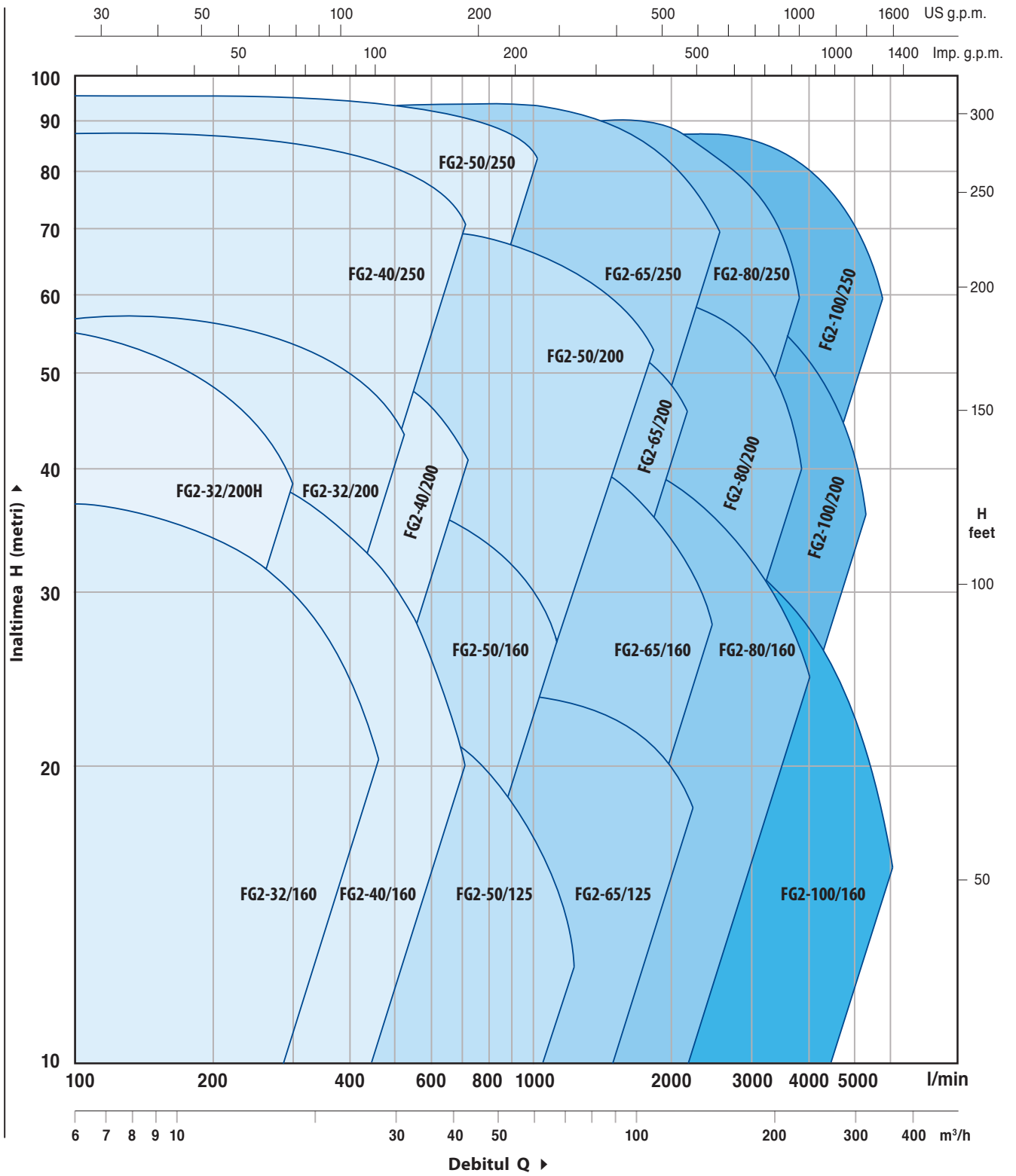

DATE DE LUCRU
n= 2900 1/min HS= 0 m

TIP pompa	MOTOR CU CUPLAJ		PRESTATII	
	kW	HP	Q l/min	H metri
FG2 32/160C	1.5	2	100 ÷ 350	24 ÷ 14
FG2 32/160B	2.2	3	100 ÷ 400	30 ÷ 17
FG2 32/160A	3	4	100 ÷ 450	37 ÷ 24
FG2 32/200C	4	5.5	100 ÷ 450	44 ÷ 31.5
FG2 32/200B	5.5	7.5	100 ÷ 500	51 ÷ 36
FG2 32/200A	7.5	10	100 ÷ 500	57 ÷ 44
FG2 32/200BH	3	4	100 ÷ 300	45 ÷ 37
FG2 32/200AH	4	5.5	100 ÷ 320	55 ÷ 44
FG2 40/160C	2.2	3	100 ÷ 600	27 ÷ 14
FG2 40/160B	3	4	100 ÷ 600	32 ÷ 20
FG2 40/160A	4	5.5	100 ÷ 700	38 ÷ 20
FG2 40/200B	5.5	7.5	100 ÷ 700	47 ÷ 28
FG2 40/200A	7.5	10	100 ÷ 700	55 ÷ 41
FG2 40/250C	9.2	12.5	100 ÷ 700	64 ÷ 47
FG2 40/250B	11	15	100 ÷ 700	71 ÷ 55
FG2 40/250A	15	20	100 ÷ 700	88 ÷ 72
FG2 50/125C	2.2	3	300 ÷ 1200	17.5 ÷ 6
FG2 50/125B	3	4	300 ÷ 1200	20.7 ÷ 9
FG2 50/125A	4	5.5	300 ÷ 1200	23.5 ÷ 13
FG2 50/160C	4	5.5	300 ÷ 1000	27 ÷ 16
FG2 50/160B	5.5	7.5	300 ÷ 1100	32 ÷ 21
FG2 50/160A	7.5	10	300 ÷ 1100	37 ÷ 27
FG2 50/200C	11	15	400 ÷ 1700	44 ÷ 30
FG2 50/200B	15	20	400 ÷ 1700	52 ÷ 38
FG2 50/200A	18.5	25	400 ÷ 1800	61 ÷ 45
FG2 50/200AR	22	30	400 ÷ 1800	69 ÷ 53
FG2 50/250D	9.2	12.5	300 ÷ 900	51 ÷ 32
FG2 50/250C	11	15	300 ÷ 900	59 ÷ 42
FG2 50/250B	15	20	300 ÷ 1000	72 ÷ 59
FG2 50/250A	18.5	25	300 ÷ 1000	85 ÷ 73
FG2 50/250AR	22	30	300 ÷ 1000	95 ÷ 83
FG2 65/125C	4	5.5	600 ÷ 1800	16 ÷ 11
FG2 65/125B	5.5	7.5	600 ÷ 2000	18 ÷ 13
FG2 65/125A	7.5	10	600 ÷ 2200	23 ÷ 18
FG2 65/160C	9.2	12.5	600 ÷ 2200	32 ÷ 22
FG2 65/160B	11	15	600 ÷ 2400	36.5 ÷ 23
FG2 65/160A	15	20	600 ÷ 2400	40.5 ÷ 28
FG2 65/200B	15	20	400 ÷ 2000	45 ÷ 35.5
FG2 65/200A	18.5	25	400 ÷ 2100	51 ÷ 40
FG2 65/200AR	22	30	400 ÷ 2100	57 ÷ 46
FG2 65/250C	30	40	400 ÷ 2350	76 ÷ 53
FG2 65/250B	37	50	400 ÷ 2500	87 ÷ 62
FG2 65/250A	45	60	400 ÷ 2600	94.5 ÷ 68

TIP pompa	MOTOR CU CUPLAJ		PRESTATII	
	kW	HP	Q l/min	H metri
FG2 80/160D	11	15	500 ÷ 4000	25 ÷ 10
FG2 80/160C	15	20	500 ÷ 4000	30 ÷ 15
FG2 80/160B	18.5	25	500 ÷ 4000	35 ÷ 20
FG2 80/160A	22	30	500 ÷ 4000	40 ÷ 25
FG2 80/200B	30	40	500 ÷ 3650	56 ÷ 34.5
FG2 80/200A	37	50	500 ÷ 3900	62 ÷ 40
FG2 80/250B	45	60	600 ÷ 3600	77 ÷ 54
FG2 80/250A	55	75	600 ÷ 3900	88.5 ÷ 60
FG2 100/160C	15	20	1000 ÷ 5000	28 ÷ 12
FG2 100/160B	18.5	25	1000 ÷ 5500	32 ÷ 13
FG2 100/160A	22	30	1000 ÷ 6000	35 ÷ 15
FG2 100/200C	30	40	800 ÷ 4650	51 ÷ 28
FG2 100/200B	37	50	800 ÷ 4900	57 ÷ 33
FG2 100/200A	45	60	800 ÷ 5250	63 ÷ 38
FG2 100/250B	55	75	800 ÷ 5150	75 ÷ 48
FG2 100/250A	75	100	800 ÷ 5750	89 ÷ 58

CAMPUL DE PRESTATIE

HS= 0 m

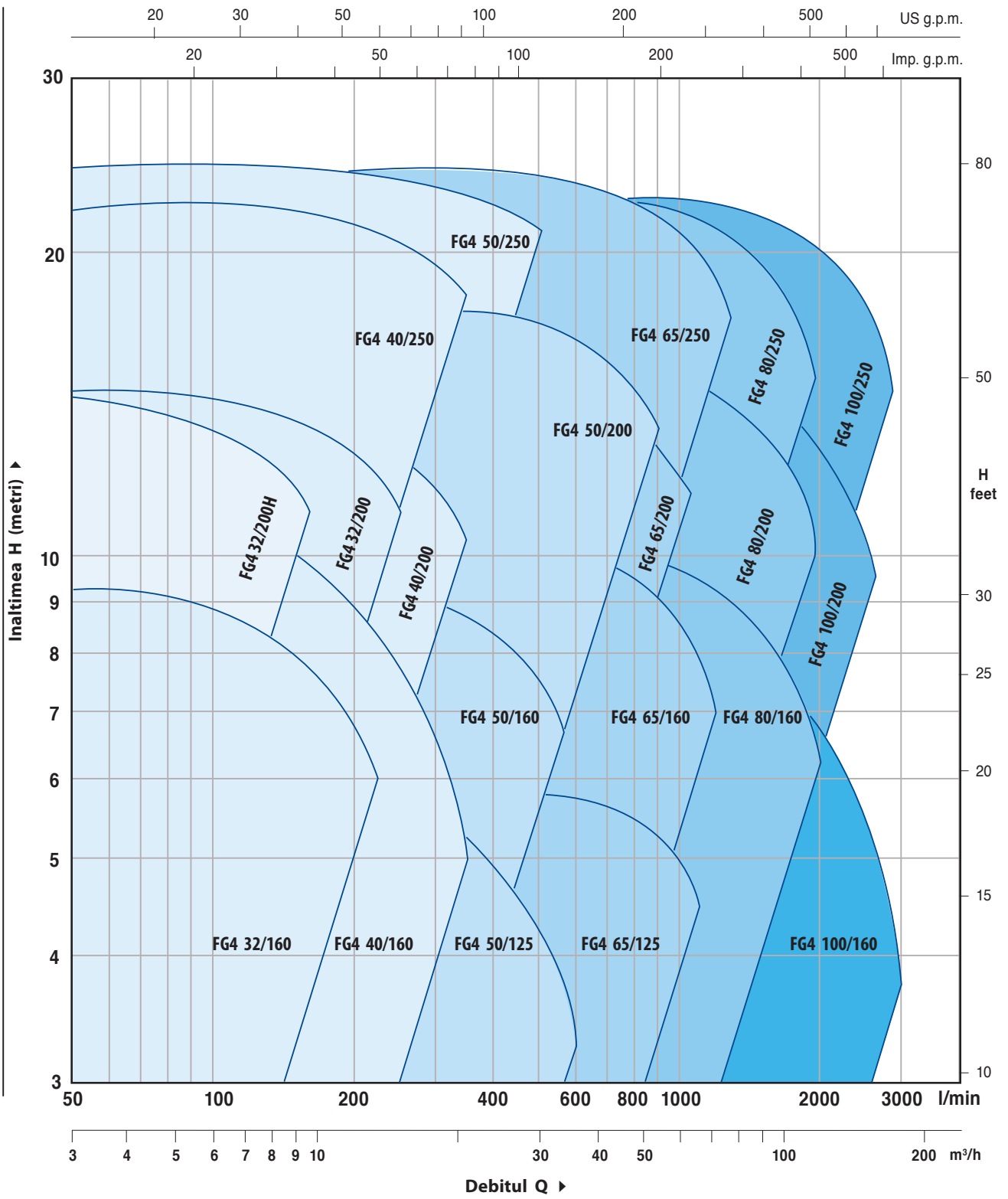

DATE DE LUCRU
n= 1450 1/min HS= 0 m

TIP pompa	MOTOR CU CUPLAJ		PRESTATII	
	kW	HP	Q l/min	H metri
FG4 32/160C	0.25	0.33	50 ÷ 175	6 ÷ 3.5
FG4 32/160B	0.37	0.5	50 ÷ 200	7.5 ÷ 4
FG4 32/160A	0.37	0.5	50 ÷ 225	9 ÷ 6
FG4 32/200C	0.55	0.75	50 ÷ 225	11 ÷ 8
FG4 32/200B	0.75	1	50 ÷ 250	12.5 ÷ 9
FG4 32/200A	1.1	1.5	50 ÷ 250	14 ÷ 11
FG4 32/200BH	0.55	0.75	50 ÷ 150	11 ÷ 9
FG4 32/200AH	0.55	0.75	50 ÷ 160	13.5 ÷ 11
FG4 40/160C	0.37	0.5	50 ÷ 300	6.5 ÷ 3.5
FG4 40/160B	0.37	0.5	50 ÷ 300	8 ÷ 5
FG4 40/160A	0.55	0.75	50 ÷ 350	9.5 ÷ 5
FG4 40/200B	0.75	1	50 ÷ 350	11.5 ÷ 7
FG4 40/200A	1.1	1.5	50 ÷ 350	13.5 ÷ 10
FG4 40/250C	1.1	1.5	50 ÷ 350	16 ÷ 11.5
FG4 40/250B	1.5	2	50 ÷ 350	17.5 ÷ 13.5
FG4 40/250A	2.2	3	50 ÷ 350	22 ÷ 18
FG4 50/125C	0.37	0.5	150 ÷ 600	4 ÷ 1.5
FG4 50/125B	0.55	0.75	150 ÷ 600	5 ÷ 2
FG4 50/125A	0.55	0.75	150 ÷ 600	6 ÷ 3
FG4 50/160C	0.55	0.75	150 ÷ 500	7 ÷ 4
FG4 50/160B	0.75	1	150 ÷ 550	8 ÷ 5
FG4 50/160A	1.1	1.5	150 ÷ 550	9 ÷ 7
FG4 50/200C	1.5	2	200 ÷ 850	11 ÷ 7.5
FG4 50/200B	2.2	3	200 ÷ 850	13 ÷ 9.5
FG4 50/200A	2.2	3	200 ÷ 900	15 ÷ 11
FG4 50/200AR	3	4	200 ÷ 900	17 ÷ 13
FG4 50/250D	1.1	1.5	150 ÷ 450	12.5 ÷ 8
FG4 50/250C	1.5	2	150 ÷ 450	14.5 ÷ 10.5
FG4 50/250B	2.2	3	150 ÷ 500	18 ÷ 14.5
FG4 50/250A	2.2	3	150 ÷ 500	21 ÷ 18
FG4 50/250AR	3	4	150 ÷ 500	24 ÷ 21
FG4 65/125C	0.55	0.75	300 ÷ 900	4 ÷ 2.5
FG4 65/125B	0.75	1	300 ÷ 1000	4.5 ÷ 3
FG4 65/125A	1.1	1.5	300 ÷ 1100	5.5 ÷ 4.5
FG4 65/160C	1.1	1.5	300 ÷ 1100	8 ÷ 5.5
FG4 65/160B	1.5	2	300 ÷ 1200	9 ÷ 5.5
FG4 65/160A	2.2	3	300 ÷ 1200	10 ÷ 7
FG4 65/200B	2.2	3	200 ÷ 1000	11 ÷ 9
FG4 65/200A	2.2	3	200 ÷ 1050	12.5 ÷ 10
FG4 65/200AR	3	4	200 ÷ 1050	14.3 ÷ 11.5
FG4 65/250C	3	4	200 ÷ 1175	19 ÷ 13
FG4 65/250B	4	5.5	200 ÷ 1250	21.5 ÷ 15.5
FG4 65/250A	5.5	7.5	200 ÷ 1300	23.5 ÷ 17

TIP pompa	MOTOR CU CUPLAJ		PRESTATII	
	kW	HP	Q l/min	H metri
FG4 80/160D	1.5	2	250 ÷ 2000	6 ÷ 2.5
FG4 80/160C	2.2	3	250 ÷ 2000	7.5 ÷ 3.5
FG4 80/160B	2.2	3	250 ÷ 2000	8.5 ÷ 5
FG4 80/160A	3	4	250 ÷ 2000	10 ÷ 6
FG4 80/200B	4	5.5	250 ÷ 1825	14 ÷ 8.5
FG4 80/200A	5.5	7.5	250 ÷ 1950	15.5 ÷ 10
FG4 80/250B	5.5	7.5	300 ÷ 1800	19 ÷ 13.5
FG4 80/250A	7.5	10	300 ÷ 1950	22 ÷ 15
FG4 100/160C	2.2	3	500 ÷ 2500	7 ÷ 3
FG4 100/160B	3	4	500 ÷ 2750	8 ÷ 3
FG4 100/160A	3	4	500 ÷ 3000	8.5 ÷ 3.5
FG4 100/200C	4	5.5	400 ÷ 2325	12.5 ÷ 7
FG4 100/200B	5.5	7.5	400 ÷ 2450	14 ÷ 8
FG4 100/200A	5.5	7.5	400 ÷ 2625	15.5 ÷ 9.5
FG4 100/250B	7.5	10	400 ÷ 2575	18.5 ÷ 12
FG4 100/250A	9.2	12.5	400 ÷ 2875	22 ÷ 14.5